

Liiketoiminta kehittyy – kehity sinäkin!



Challenges in Training Agile Methodologies

Pentti Virtanen in Turku Agile Day 2009 – 19.3.2009

Helsinki, Tampere, Turku, Tukholma, Göteborg | www.tieturi.fi

Tieturi



- Leading supplier of business development, IT-, technology and project management training in Finland
- Public courses, seminars and conferences
- Certification programs
- Tailored customer specific courses

Pentti.Virtanen at tieturi.fi

Pentti Virtanen

- **Practical software engineering projects since 1981**
 - Analyst,
 - Project manager, line manager and
 - Software process engineer
 - Trainer in Tieturi from 2003
- **Degree:**
 - Ph. D. in Computer Science (Thesis: "Measuring and improving component-based software development") at the University of Turku
- **Areas of expertise:**
 - Development of software development methodologies and processes
 - Measurement, productivity, agility (Certified Scrum Practitioner)
 - Objects and components
 - Project management, analysis, design, programming

Agenda

Expectations
Selling Agility?
Learning styles
Hard things in agility
Making it work at home
Summary



Liiketoiminta kehittyy – kehity sinäkin!



Expectations

Helsinki, Tampere, Turku, Tukholma, Göteborg | www.tieturi.fi

What do the management expect?



Manager has heard about better time-to-market, productivity, quality, ...



Expected results



What do the participants expect?

- Learners
 - Want to learn?
- Experts
 - Know it already
- Vacationers
 - Better here than at work
- Prisoners
 - Here because the boss told
- Early adopters
 - Eager to learn and try things
- Mainstream
 - Follow others
 - Skeptic
- Personal agenda
 - Status
 - Promotion
 - Only if it is related to my role



Learning styles

- People learn when they
 - See it
 - Hear it
 - Do it
- Proportions of the pure styles vary
- Mix of styles in a course
- Not just a class course
 - Online courses
 - Books
 - Papers, web



Games, lectures and discussions

- Scrum games
 - Normal part of CSM trainings
 - Getting the idea
 - Happens sometimes
 - Take time
 - Requires arrangements
- Group discussion
 - Activates the people
 - Briefings helps in getting the idea
- Lectures
 - Fast to deliver the material
 - Do you know how much they forget?
 - Email and mobile calls
 - Doing “real” work
- Questions and answers
 - What about wallflowers
 - Connects course to real life

We want to be certified

- Controversial topic in Agile community
- Certified ScrumMaster
 - Participate in 2 days training
 - Personal certificate
- Corporate level
 - Want assurance that their methods are the best
 - Used for sales
 - We have 100 CSMs
 - Quality standards work this way too
- Challenge when this narrows the scope



Liiketoiminta kehittyy – kehity sinäkin!



Selling Agility?

Helsinki, Tampere, Turku, Tukholma, Göteborg | www.tieturi.fi

Am I supposed to sell agility?

- Employers expect
 - Business benefits
 - Adoption of new practices
- Change resistance of the participants
 - Healthy skepticism
 - Do not forget pitfalls
 - Even if you do not have time for that
 - Success stories are needed
 - Rationalizing the practices

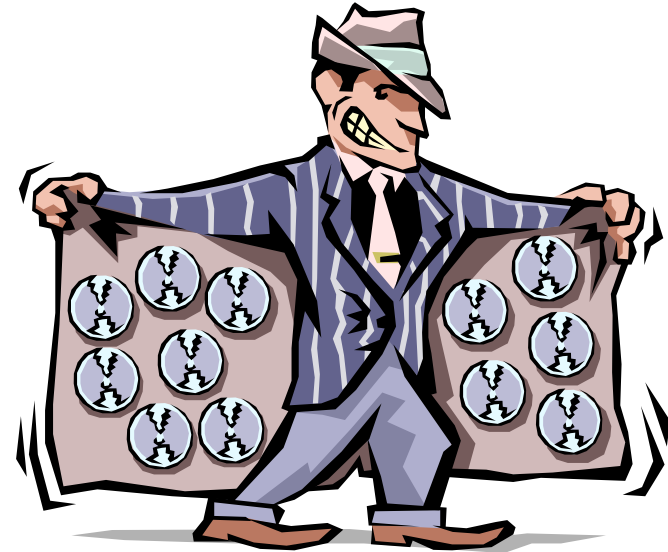

Proof that it works

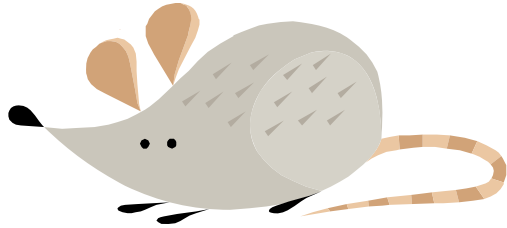

- Test rat for testing agile practices
- Mathematical proof by queue theory

Success stories:

- Nokia Siemens Networks
 - Global environment with multiple sites
- Some other published
 - Patient keeper (Jeff Sutherland)
 - F-Secure
 - British Telecom
 - Tele Atlas
- Agile surveys: high satisfaction rates
 - VersionOne
 - Ambysoft

Pitfalls

- Existence assumed
- Commonly mentioned
 - Ignoring one or more agile practices
 - Using agile practices not possible in all kind of projects
 - Agile practices not possible in every environment
 - Agile practices are simple but hard
 - Devil is in the details



Hard core agility

Agility is simple but hard

Lure of mass production

- Mass production using predictive defined process control
 - Will repeatedly produce acceptable quality output
 - Use whenever possible to price it as a commodity
- Do we have benefits due to
 - Larger scale?
 - Minimal competence
- Costs due to
 - Task switching
 - Delays
 - Loss of information when using division of labor
 - Replacing people



Empirical process control in Scrum

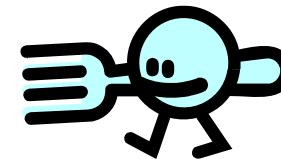

Processes and tools

Agile manifesto

- ✓ Individuals and interactions over processes and tools
- ✓ Working software over comprehensive documentation
- ✓ Customer collaboration over contract negotiation
- ✓ Responding to change over following a plan

- **The secret of agility is not in**
 - Scrum Flow,
 - XP practices
- **Tools are not that important**
- **But ..**
 - **This is what people want to hear**



Cross-functional organization

- **Cross-functional with no roles**
 - Programmers
 - Testers
 - Analysts and designers
 - Technical writers
 - ...
- Responsible for committing to work

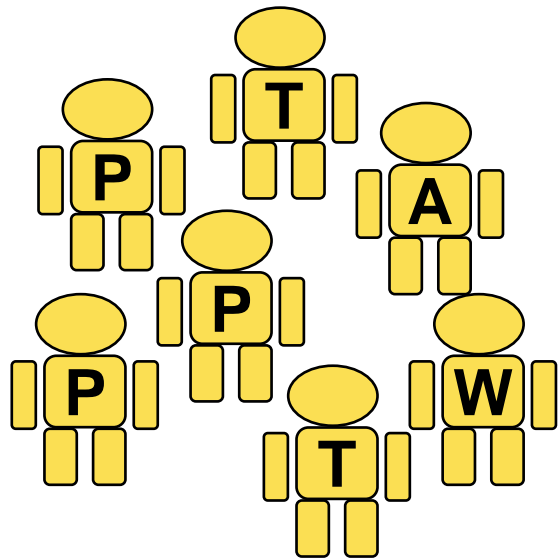

Feature teams

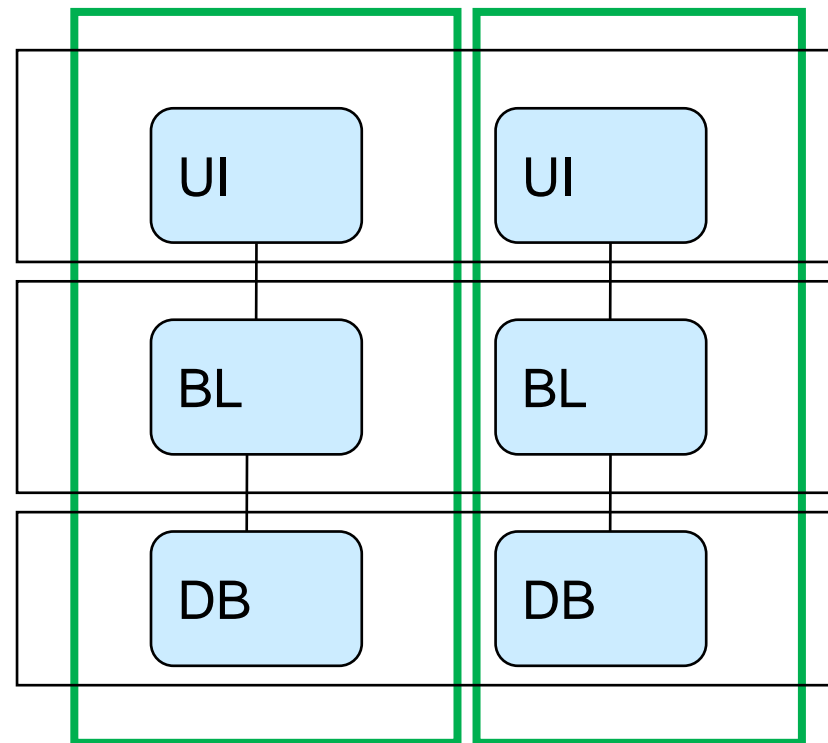

“Requirements” considered harmful

- “Requirements” are actually business decisions related to the product to be developed
- There are high level business decisions and detailed business decisions
- Business people make business decisions
- There are high level technical decisions (architectures) and detailed technical decisions (code details)
- Technical people make technical decisions
- **There is no need to make all business decisions before any technical decisions**
- In reality last business decision is done when the product is (almost) ready
 - It is based on feedback of the developed product

Self-organizing Teams

Toyotas real innovation was to harness the intellect of “ordinary” employees

Team performance

- Teams and people do their best work when they aren't interrupted
- Teams improve most when they solve their own problems;
- Broad-band, fact-to-face communications is the most productive way for teams to work together.
- Team rooms

Psychology
Skill, pride, expertise, confidence
and cooperation make the difference

Team motivation

1. People are most productive when they manage themselves
2. People take their commitment more seriously than other people's commitment for them
3. People have many creative moments during down time
4. People always do the best they can
5. Under pressure to “work harder,” developers automatically and increasingly reduce quality.

Full agility

- Scrum
- Lean Software Development
- Extreme Programming
 - Test driven development
- Modified engineering practices
 - Testing
 - Integration
 - Requirements
 - Product owners

Agility training and coaching in Tieturi 2009

Cornerstones of Agility - 3 h on-line (spoken in Finnish) or a lecture
Agile Software Development with Scrum - 1 d class training for Scrum Teams
Agile Project Management with Scrum - 2 d class training for Scrum Masters
Agile and Lean Software Development with Scrum - 2 d class training for Software Developers
Managing Agile Software Projects - 3 d class training for Project managers and Scrum Masters
Agile Practices and their Adoption - 2 d class training for Managers
Extreme Programming - 1+1 d class training for Software Developers
Test Driven Development - 2 d class training for Software Developers and Testers
Scrum for Product Owners - 1 d class training & coaching for Product Owners
Agile Coaching for organizations - ask for details
Agile Visual Studio Team System Workshop - 2 d
Advanced Agile SW Development - 1 d class training for ScrumMasters and Managers

Liiketoiminta kehittyy – kehity sinäkin!



Making it Work at Home

Helsinki, Tampere, Turku, Tukholma, Göteborg | www.tieturi.fi

Organization's support

- Corporate culture
 - Eats strategy as a breakfast
- Agile island inside a bureaucracy
 - Management
 - Sales
 - Marketing
 - hardware
- Systems still in use
 - Quality system
 - Reporting
- Customers and vendors



Our environment

- Outsourced
- Contract based
- Open space instead of team rooms
- Distributed teams
- Development environment
 - Consistent, integrated
- Communication
 - Community
 - Tools
 -



Delivering crap

- Deliver potentially shippable increment of functionality every month
- Pressure
- Limiting work to capacity not possible

- Technical debt
- (critical) error correction consumes most of the resources
- Spiral that destroys



Lack of skills

- Cross-functional team with no roles
- To estimate work that others do?
- Helping each other
- Reduce delays
- Optimize the whole

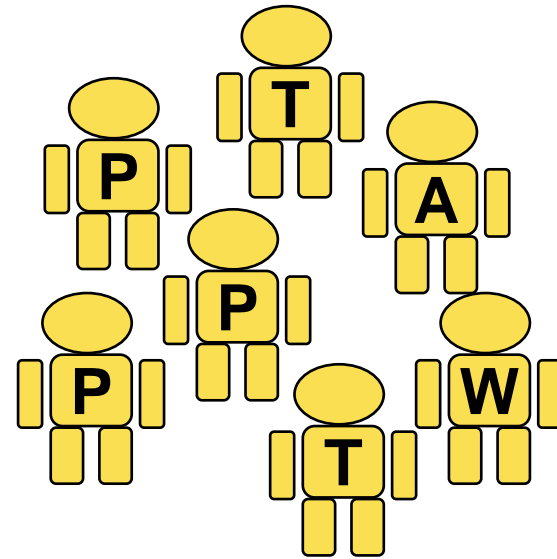

Continuous improvement

- Scrum retrospectives
 - Essential part of the whole
- Impediments are
 - Difficult to remove
 - Easy to forget/ignore
- Business as usual
 - Easier than continuous change
- Authority
 - Changes are often outside team circle of authority



Deming Cycle:
Plan, Do,
Check, Act
(PDCA)

Liiketoiminta kehittyy – kehity sinäkin!



Summary

Helsinki, Tampere, Turku, Tukholma, Göteborg | www.tieturi.fi

Summary

Training challenges

- Unrealistic and inconsistent expectations
- Different learners
- Hard core of agility
- Doing it at home

Business is evolving, you should too.



Full Agility From Tieturi

Training and coaching 2009

Helsinki, Tampere, Turku, Tukholma, Göteborg | www.tieturi.fi

19.3.2009



It is not just Scrum

But ...

Agility training and coaching in Tieturi 2009

Cornerstones of Agility – 3 h on-line (spoken in Finnish) or a lecture

Agile Software Development with Scrum – 1 d class training for Scrum Teams

Agile Project Management with Scrum – 2 d class training for Scrum Masters

Agile and Lean Software Development with Scrum – 2 d class training for Software Developers

Managing Agile Software Projects – 3 d class training for Project managers and Scrum Masters

Agile Practices and their Adoption – 2 d class training for Managers

Extreme Programming – 1+1 d class training for Software Developers

Test Driven Development – 2 d workshop training for Software Developers

Scrum and Testing – 2 d workshop for Scrum Teams

Scrum for Product Owners – 1 d class training & coaching for Product Owners

Agile Coaching for organizations – ask for details

Agile Visual Studio Team System Workshop – 2 d

Advanced Agile SW Development – 1 d class training for ScrumMasters and Managers



Starters

What is agility? What is Scrum?

- For everyone
- To understand the basic ideas of agility
- To know the best agile practices
- To know the famous agile frameworks
- Lecture for teams
 - Suitable for a talk in an offsite meeting
- Online course to start today



- Scrum for the whole team
 - Short introduction to agility
 - Scrum glossary
 - Scrum flow explained in details
-
- Covers the certified ScrumMaster course topics, but
 - Tight schedule
 - Less games



- Scrum for the ScrumMasters
 - Scrum basics
 - Scrum games
- Certified ScrumMaster training or
- Without Scrum Alliance certificate



- For
 - Managers
 - ScrumMasters
 - Developers
- Compact package including
 - Agility
 - Scrum
 - Lean Software development



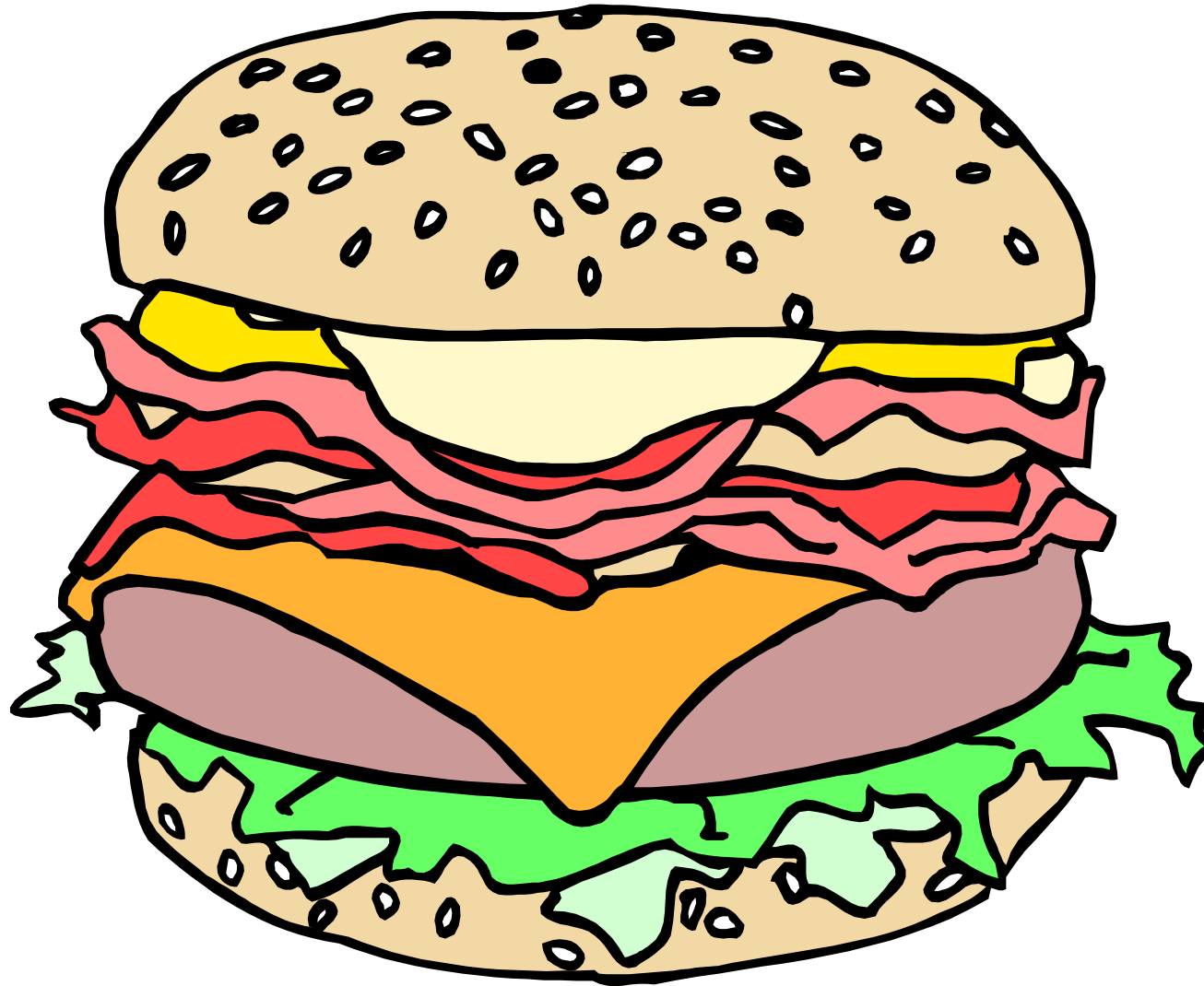

The beef included

This all has something to do with Software Engineering

- Whole project management for
 - ScrumMasters
 - Team leaders
- Includes Scrum but not just that
 - Lean
 - Extreme programming
 - Testing
 - Self-organizing teams
- How to apply agility to a project
 - Use your own real life project as an example

- What is lean and agile software development?
- How to introduce it to an organization ?
- Management perspective to agility

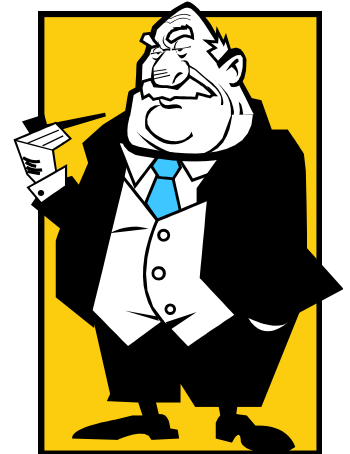

- Extreme agile practices for
 - Developers
 - Managers
 - ScrumMasters
- 2nd day is optional and tool specific
 - Java
 - .NET

- Real programming with
 - Java
 - .NET
- Junit, Nunit, Mock frameworks
- Unit testing patterns
- Can you build an enterprise level application with test driven development techniques?

- Role-less testing for everyone
 - Developers
 - Managers
 - ScrumMasters
 - Testers
- Sharing testing work in practice
 - Context driven testing
 - Viewpoints and responsibilities suitable for scrum teams
 - Learning techniques
 - Documentation techniques
 - Conducting testing sessions
 - Heuristic testing
 - Exploratory testing
- Planning testing schedules for sprints
 - Estimation techniques



Specific

Tools, consulting, distributed, large scale

- For product owners
- Agile business cases and requirements
- Certified product owner 2 days
 - Includes Scrum theory
- Add-on - 1 days
 - Scrum basics as a prerequisite
 - Coaching mode using real life projects

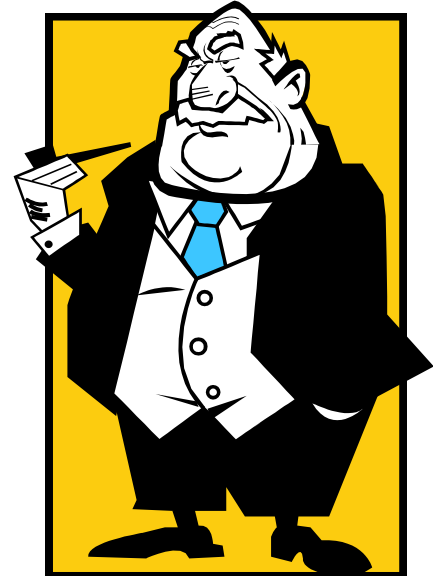

- Agile adoption using Tieturi's
 - Adoption approach
 - Training
 - Coaching
 - Consulting



Agile Visual Studio Team System Workshop – 2 d

- Hands-on lab for project teams on using VSTS in an agile project
 - Project templates
 - Work item tracking
 - Role specific tools
 - Reporting
 - Test Driven Development
 - Continuous Integration

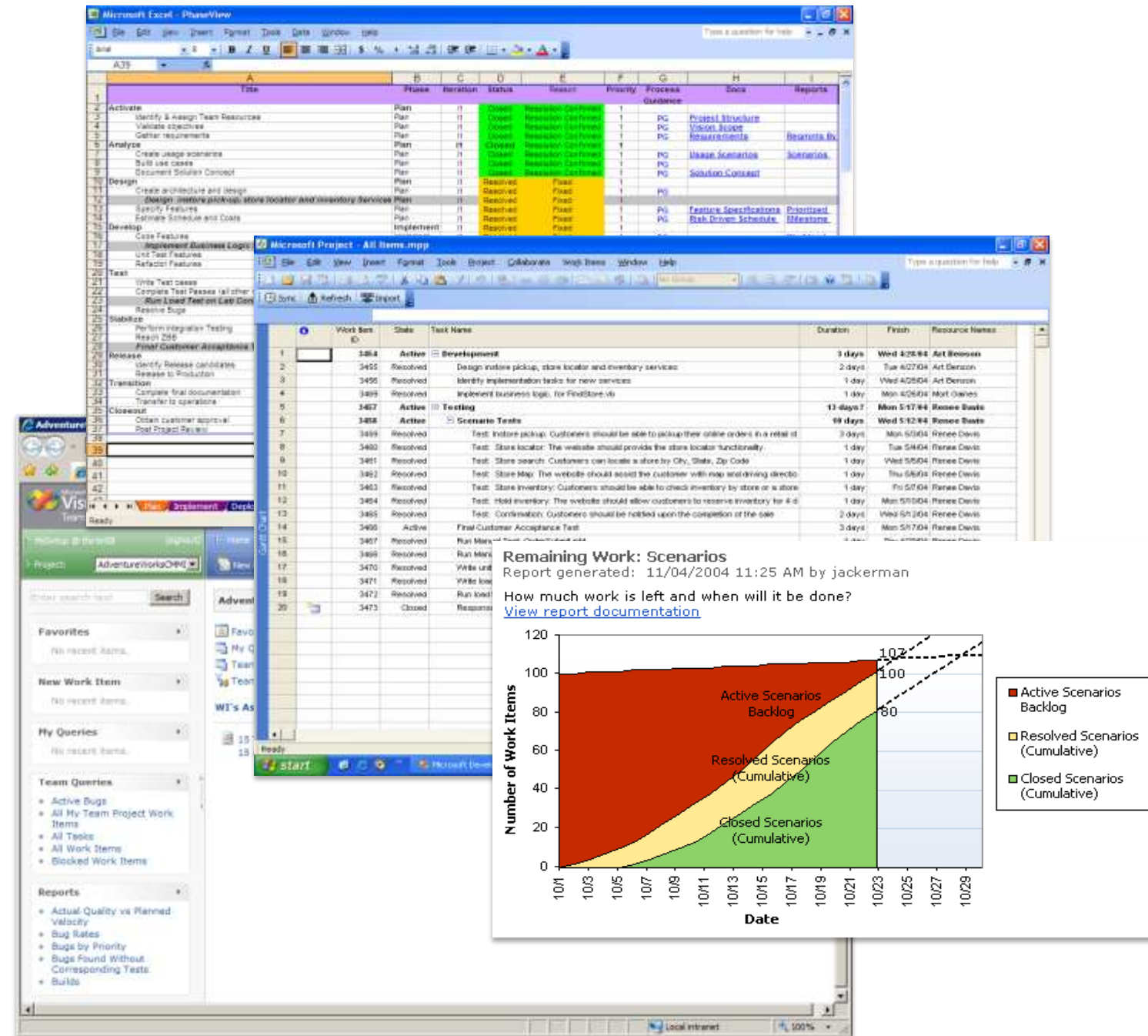

- Advanced topics for
 - Scrum masters
 - Managers
 - Developers
- Discussion about
 - Lean software development
 - Enterprise level agility
 - Combining agility with traditional
 - Improved quality
 - Distributed and outsourced agility
 - Agile adoption

